

# B150 Benchtop



INKCUPS NOW

[www.inkcups.com](http://www.inkcups.com)

# Inkcups Now Pad Print Training Video

To view the video,  
please scan the  
following icon  
with your  
QR reader.



Or visit:

<http://youtu.be/2b8-BUGfoU0>



[www.inkcups.com](http://www.inkcups.com)

# Table of Contents

## **Chapter 1: Learning about Pad Printing**

Applications of pad printing.....	3
Principles of pad printing.....	3
Inking the plate.....	3
Ink pick up and transfer.....	4
Thin film process.....	4
Items to start a pad printing job.....	4
The etched plate.....	5
Silicone pad.....	5
Ink.....	6
Pad printing machine.....	6

## **Chapter 2: A Quick Review on Your Pad Printer**

Features.....	7
Specifications.....	7
Illustration of main components (left view).....	8
Illustration of main components (right view).....	9
Illustration of ink cup system.....	10
Wiring diagram for main circuit board.....	11
Wiring diagram for lighting lamps.....	12

## **Chapter 3: Installation, Setting & Adjustment**

Install the machine & initial setup.....	13
Install ink cup & plate.....	14
Tune up the ink cup.....	15
Dismount ink cup & plate.....	16
Install & set the printing pad.....	17
Install fixtures.....	17
Set & adjust the worktable.....	18

**Chapter 4: Operating Your Machine**

Choose your desired printing program..... 19

Set the frequency of ink pick up and printing..... 19

Set to print continuously or to print in single cycle..... 20

Set the stopping position during single cycle printing..... 20

Set to print or to ink the plate only..... 20

Set delay time..... 21

Manually operating the pad..... 21

Use of counter..... 21

Use of foot switch..... 21

Use of emergency switch..... 21

Use of side protection cover..... 22

Speed up the pads' movement..... 22

Light up in printing..... 22

**Chapter 5: Tips for Maintaining Your Machine**

Tips for maintaining your machine..... 23

**Chapter 6: Troubleshooting Guide**

Printing problems troubleshooting..... 24

Machinery problems troubleshooting..... 25

**Chapter 7: Spare Parts Listing**

Part listing..... 30

**Chapter**

**1**

# Learning about Pad Printing

**APPLICATIONS OF PAD PRINTING**

Transfer pad printing or tampo printing, commonly known as pad printing, is an "indirect offset gravure" printing process. It was originally used in the watch making industry in Switzerland to decorate watch faces. Pad printing has now developed to a point where it is one of the major methods of printing and decorating the surfaces of objects like:

- ❖ Gifts and premiums: pens, keychains, lighters
- ❖ Sport items: golf balls, golf tees
- ❖ Computer items: computer case, keyboards, keypads, mouse
- ❖ Electrical items: mobile phones, telephones, cameras, radio, TV case.
- ❖ Leisure items: CD
- ❖ Garments

**PRINCIPLES OF PAD PRINTING**

The basic process is very simple. The Image to be printed is etched into a printing plate. This etching is filled with ink by the inking mechanism. A smooth flexible silicone pad takes up most of the ink from the plate and transfers it to the components.

**INKING THE PLATE**

There are various methods of inking the plate. All Inkcups Now pad printing machines use a closed cup inking system. When the cups travels forward on the plate the ink reservoir inside floods the image, as the cups is driven back the ceramic ring doctors away the excess ink leaving only the etched areas full. Thinner then evaporates from the exposed ink and forms a tacky surface which the silicone pad can then pick up.

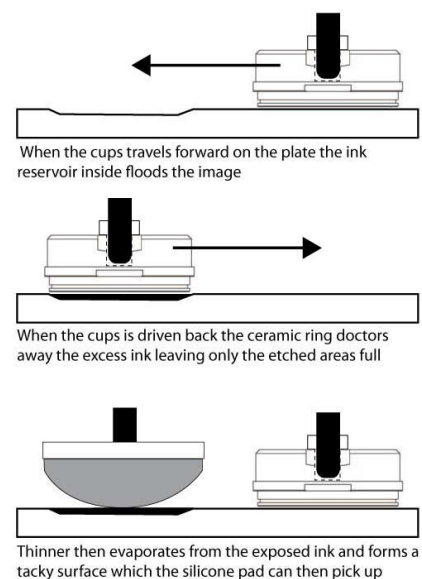

**INK PICK UP AND TRANSFER**

As the pad lifts, the tacky surface of the ink clings to the pad and lifts out of the etch. This layer of ink is carried towards the print area. During the action, some of the solvent evaporates from the exposed surface of the ink on the pad and this surface becomes tacky. When the pad contacts the components, the film of ink sticks to the surface and separates from the pad as it lifts up. The pad has to be shaped such that when it compresses, the pad surface describes rolling motion. This motion is important as it squeezes out the air over the plate and the ink surface.

**THIN FILM PROCESS**

The ideal situation is when the maximum amount of ink is picked out of the etch by the pad and all of the ink film is transferred from the pad to the object. Pad printing is a thin film process with an etch depth of 25 microns (1 micron is 0.001 of a mm) of this wet ink film, 60% is solvent which evaporates leaving only 4 microns of dried ink deposit. It is easy to see how susceptible such a thin film can be to changing temperatures, humidity levels, static charges, and variations in airflow. Controlling the rate of evaporation of the solvents from the ink and maintaining the correct solvent balance are the keys to successful pad printing. If the solvents evaporate too quickly the ink might not even pick up from the plate because it has dried in the etched portion of the plate. If the solvents evaporate too slowly, the surface of the ink may not be tacky enough to stick to the pad and lift from the etch. Both conditions, although extremes, will have the same effect -- little or no ink on the pad. Having picked some ink up from the etch onto the pad, if solvents evaporate too quickly, ink dries and stays on the pad. If they evaporate too slowly, only some ink will release from the pad onto the substrate. Therefore, it is important to have the right time for ink pick up and printing.

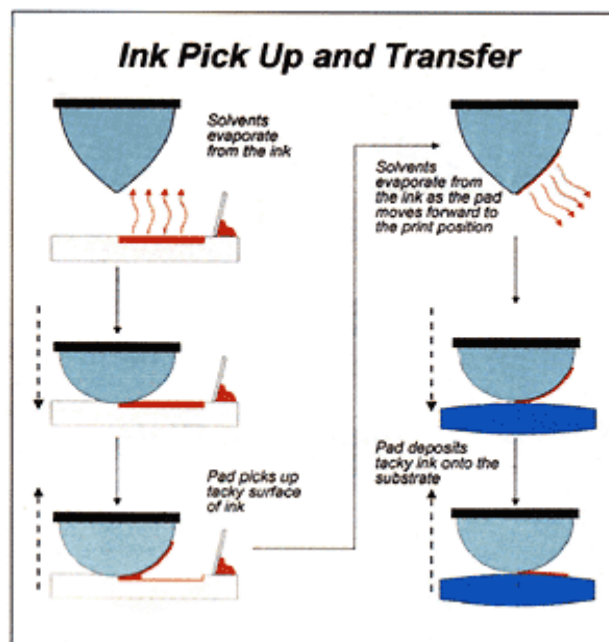

**ITEMS TO START A PAD PRINTING JOB**

- ❖ Etched plate
- ❖ Silicone pad
- ❖ Ink and thinner
- ❖ Fixture

## THE ETCHED PLATE

There are four main types of etched plate:

1. Thick steel
2. Thin steel
3. Plastic photopolymer
4. Laser

In all cases except laser plates, the image is created photographically. A photopositive is first produced. This must read correctly with the emulsion towards the viewer. Steel plates are coated with a photosensitive coating and the plastic is already photosensitive. The photopositive is then placed on the surface of the plate. The plates with the photosensitive attached are exposed to ultra violet light. This hardens the non-image areas, leaving the image areas to be washed away. In the case of the plastic polymers, either water or a mix of water and alcohol are used. Once washed out, the plate must be dried. This is a simple process.

These photopolymer plates will last up to 20,000 cycles, although care is required in setting the machine. Thick steel (5mm - 10mm) etched plates are preferred when runs are likely to be as high as 500,000 upwards. Once the image has been exposed and washed out, the metal itself has to be etched with ferric chloride or hydrochloric acid. An alternative is to use thin steel plates which can be purchased with the photosensitive coating already applied. These still require the use of an aggressive etching medium but the fact that they are pre-coated with the photosensitive emulsion makes processing a more practical proposition for you. In terms of quality of print, Laser plates offer the best image quality and highest degree of repeatability, photopolymer gives the next best results followed by thick steel and finally thin steel. From the point of view of using the plates in production, the thick steel is by far and away the best followed by thin steel and finally plastic photopolymer. The differences in print quality will only be seen if you are doing highly critical work.

The depth and quality of etch is very important. Normally the depth would be 25 microns. For large areas the depth may increase to 30 microns. It is only in a very special application that it would be any greater than this. The etch depth must be consistent across the plate and there must be no irregularities in the bottom of the etch. The image printed will only be as good as the etch. Some steel plates are made of inferior quality steel with a poor crystalline structure. Flaws in the steel will show as a poor etch and consequently a faulty print.

## SILICONE PAD

The heart of the pad printing process, as the name suggests, is the printing pad, which is made of silicone rubber. The purpose of this pad is to lift the image out of the etching and place it onto the object. Because the pad is flexible, it enables many different shapes to be

printed. It must be able to pick up as much of the ink from the etched portion of the plate as possible and release all that it picks up onto the object without any perceptible distortion. There are 5 factors which affect this process:

- 1 The shape of the pad
- 2 The hardness (durometer) of the pad
- 3 The condition of the surface of the pad
- 4 The material that the pad is made from
5. The part holding fixture

The question that is always asked is which pad should be used to print a particular job. There is no definitive answer, as there are thousands of different shapes of pad. They tend to come in three basic shapes: round, rectangular, and square, and one of these is generally likely to do the job. The shape has to be such that when the pad contacts the plate and then the object to be printed, the surface of the pad rolls over the image. This required rolling action and the size and shape of the image, to a large extent, will determine the pad that you use. Unless the surface to be printed onto is very irregular, then the rule is the harder the pad the better the ink transfer. The ideal printing surface of the pad is very smooth but slightly matt. If pads when new are very shiny it is necessary to dull the surface to achieve a satisfactory print. This can be done by carefully rubbing the pad with a soft tissue soaked in solvent. Care must be taken not to damage this surface. Maintaining surface quality is very important. The pad must be changed if it shows signs of wear. Life of a pad is about 50,000 prints.

## **INK**

Pad printing inks are quick drying because of the thin film that is required. You should choose the ink according to the material (substrate) to be printed.

## **PAD PRINTING MACHINE**

There are different types of pad printing machines:

- ❖ Manual machines
- ❖ Semi-automatic machines
- ❖ Fully automatic machines

Pad printers can be also made to open ink tray or closed ink cup system. The advantage of open ink tray system is that it is normally good for large area printing. While closed ink cup system is environmentally friendly and has no smell. Besides those basic printing machines, automatic pad cleaning system or automatic loading and unloading system is also available.



**Chapter**

**2**

# A Quick Review on Your Pad Printer

INKCUPS NOW series pad printers are developed for those customers of high quality printing requirements. Worldwide reputed parts such as German’s “Festo” pneumatic parts and Panasonic electric parts are used. All machines undergo rigid quality control to ensure every machine meets your requirements.

**FEATURES**

- ❖ Advanced microprocessor and computerized control system are adopted.
- ❖ Multi-function program key is set for your convenience of choosing printing program.
- ❖ User-friendly designed control panel with built-in enlarged LED digital counter.
- ❖ Protection covers are installed at two sides of the machine to ensure the safety of user. When the protection cover is opened or unlocked, the machine will stop running.
- ❖ Foot switch is guarded to ensure no unintended operation.
- ❖ Emergency switch is installed.
- ❖ Lamps are installed for printing and repairing so you can see better and clearer.
- ❖ Ink cup system is adopted so you can use less inks and thinners.
- ❖ Optional parts like: programmable logic control (PLC) system, auto pad cleaning system, auto loading and unloading system, are available for your choice.

**SPECIFICATIONS**

Model no.	ICN-B150
No. of color	1
Plate size	160 x 360mm
Max. printing area	Φ140mm (5.5")
Max. printing speed	15 – 35 pcs./min. (Printing speed for ink cup machine is highly depend on the thickness of ink. The thinner the ink is, the faster the machine can be run.)
Power supply	AC 100-240V, 50-60Hz, 10W
Air Pressure	0.5-0.65MPa/cm <sup>2</sup>
Air consumption	4.4L
Machine dimension	35" x 19" x 30"
Packing dimension	42" x 42" x38"
Net weight	260lb
Gross weight	305lb

ILLUSTRATION OF MAIN COMPONENTS (LEFT VIEW)

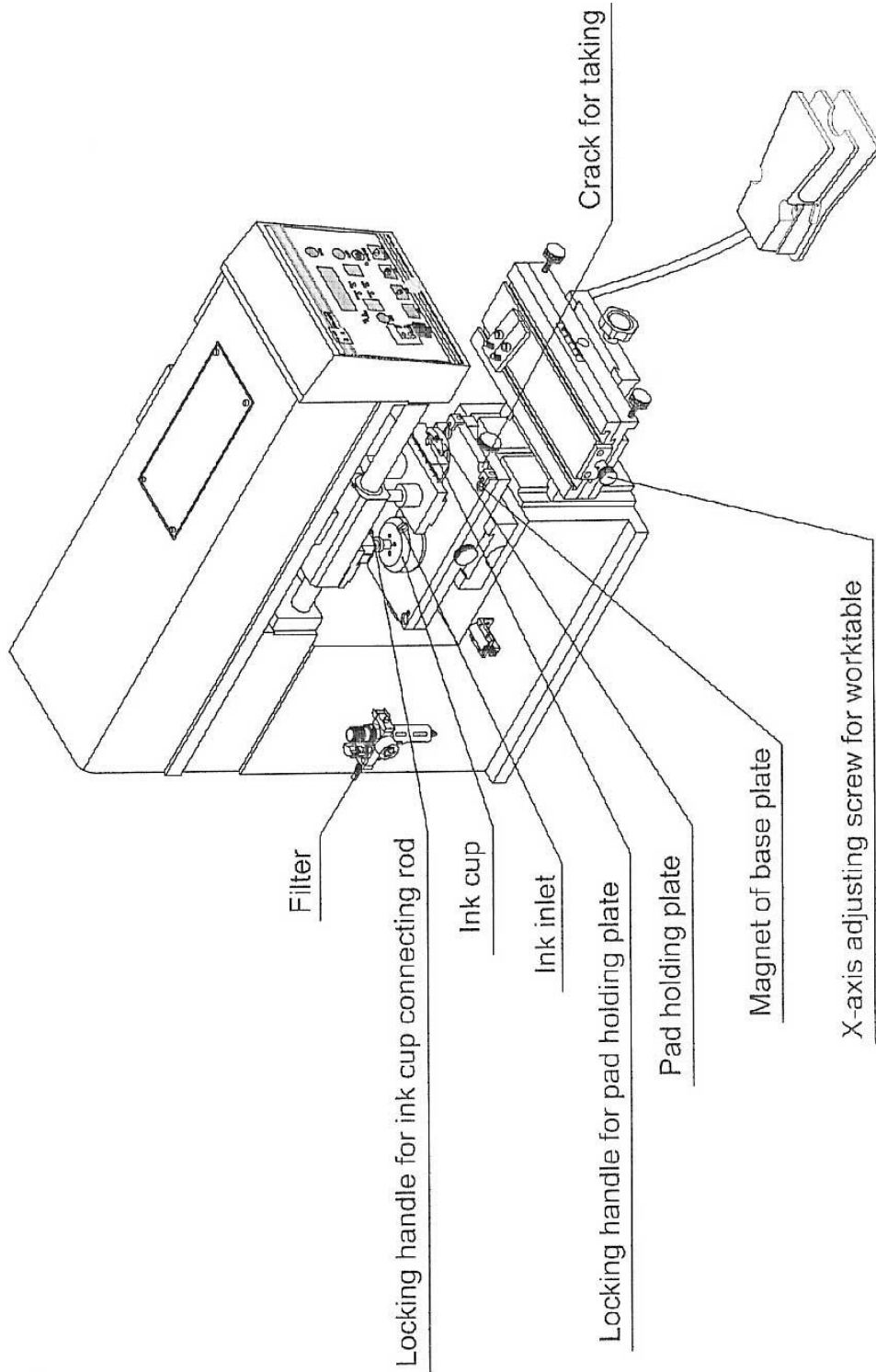

ICN-B150 Illustration of main components

ILLUSTRATION OF MAIN COMPONENTS (RIGHT VIEW)

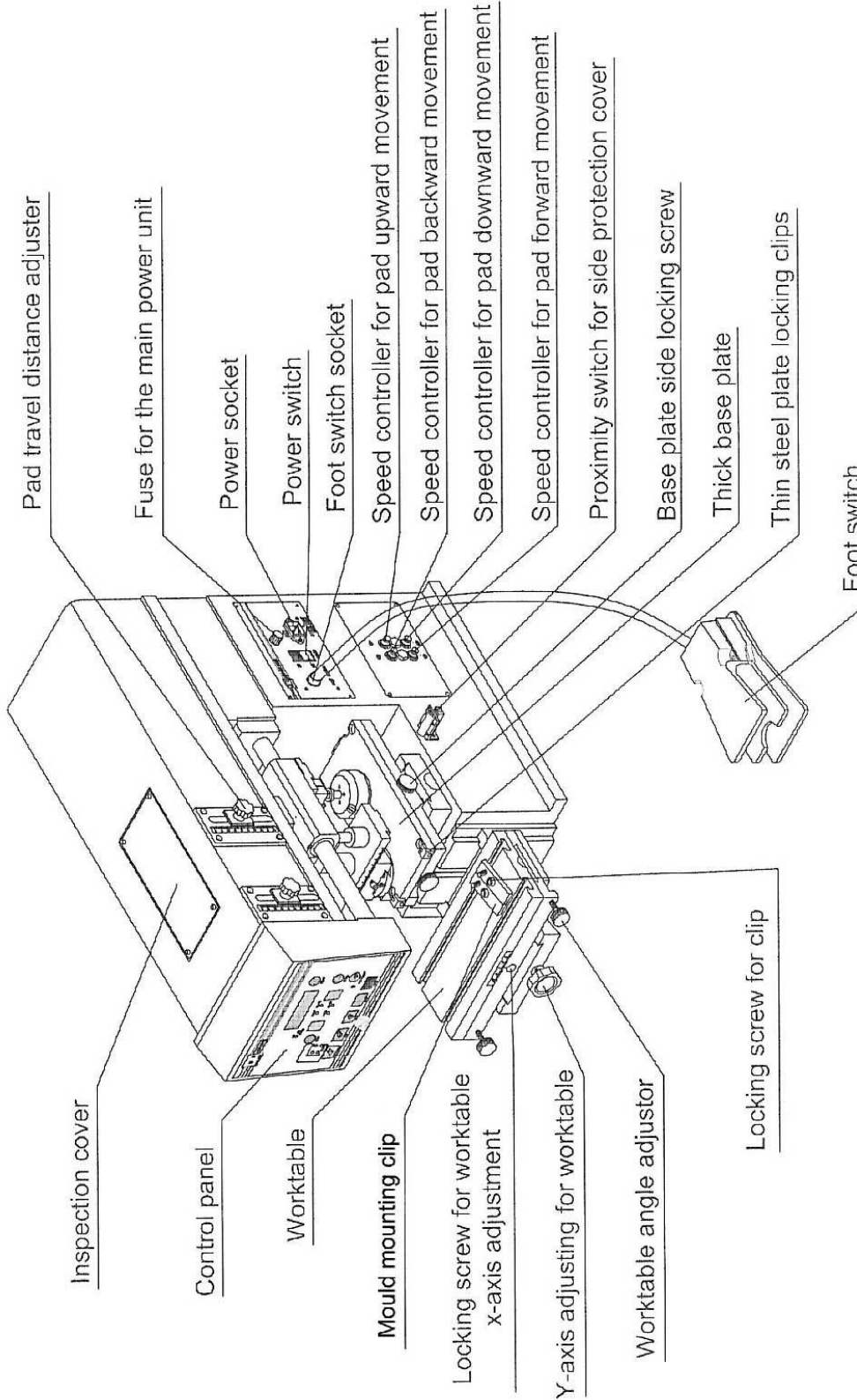

ICN-B150 Illustration of main components

ILLUSTRATION OF INK CUP SYSTEM

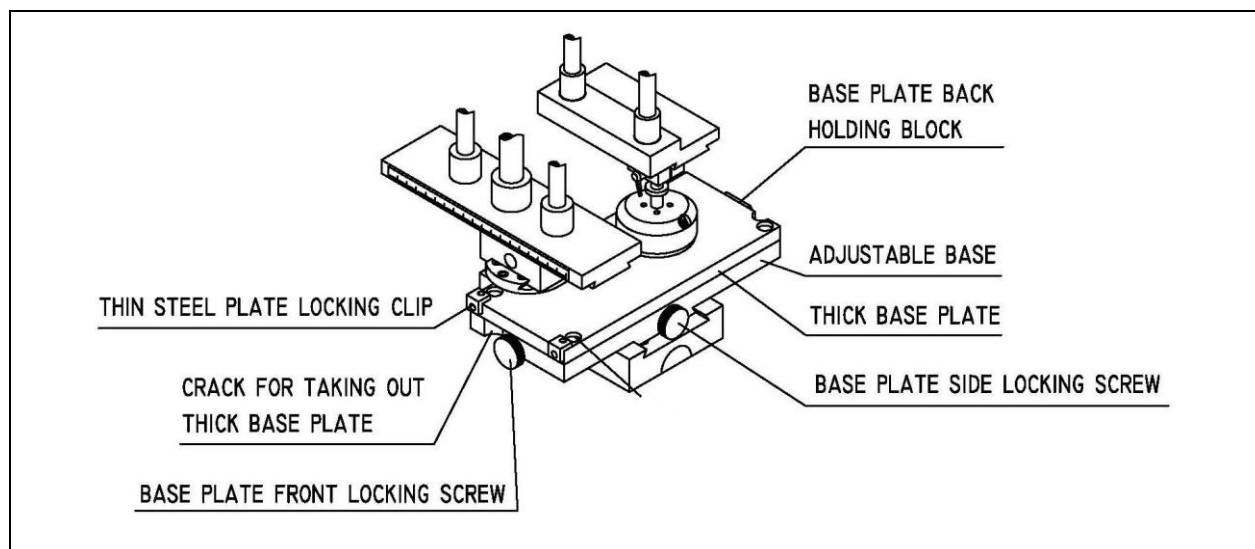
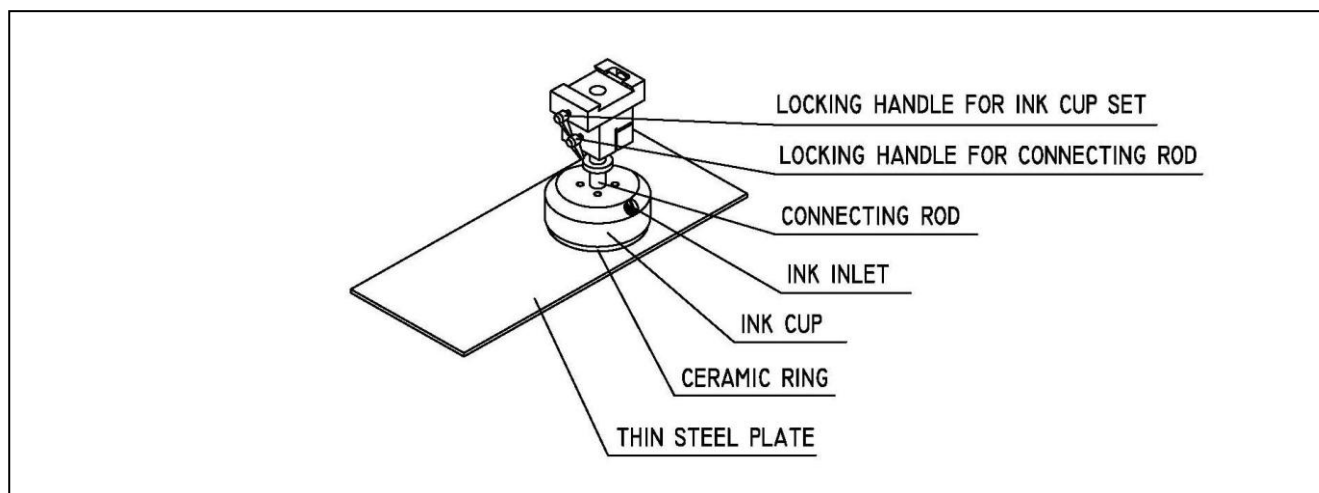

**WIRING DIAGRAM FOR MAIN CIRCUIT BOARD**

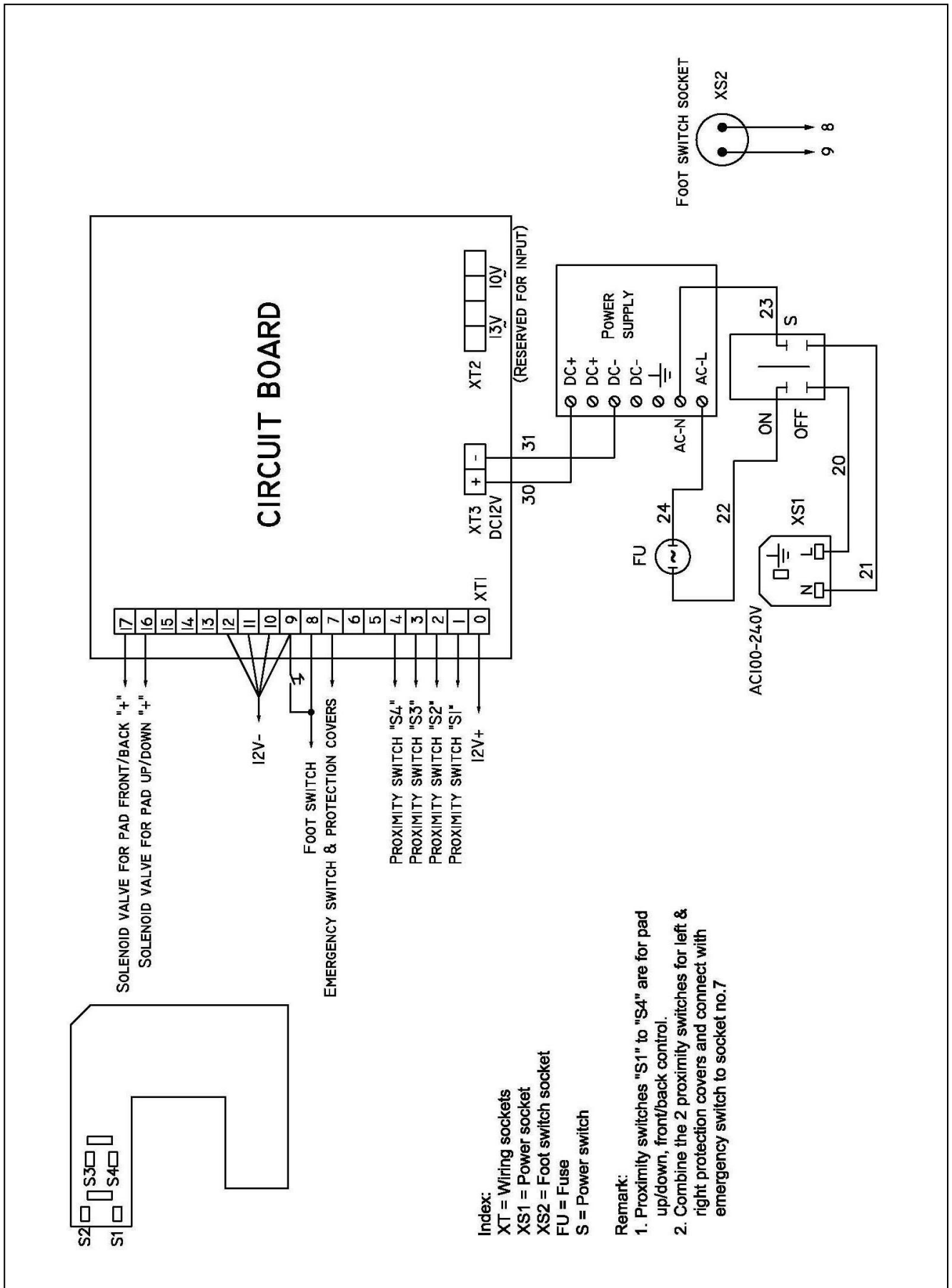

**WIRING DIAGRAM FOR LIGHTING LAMPS**

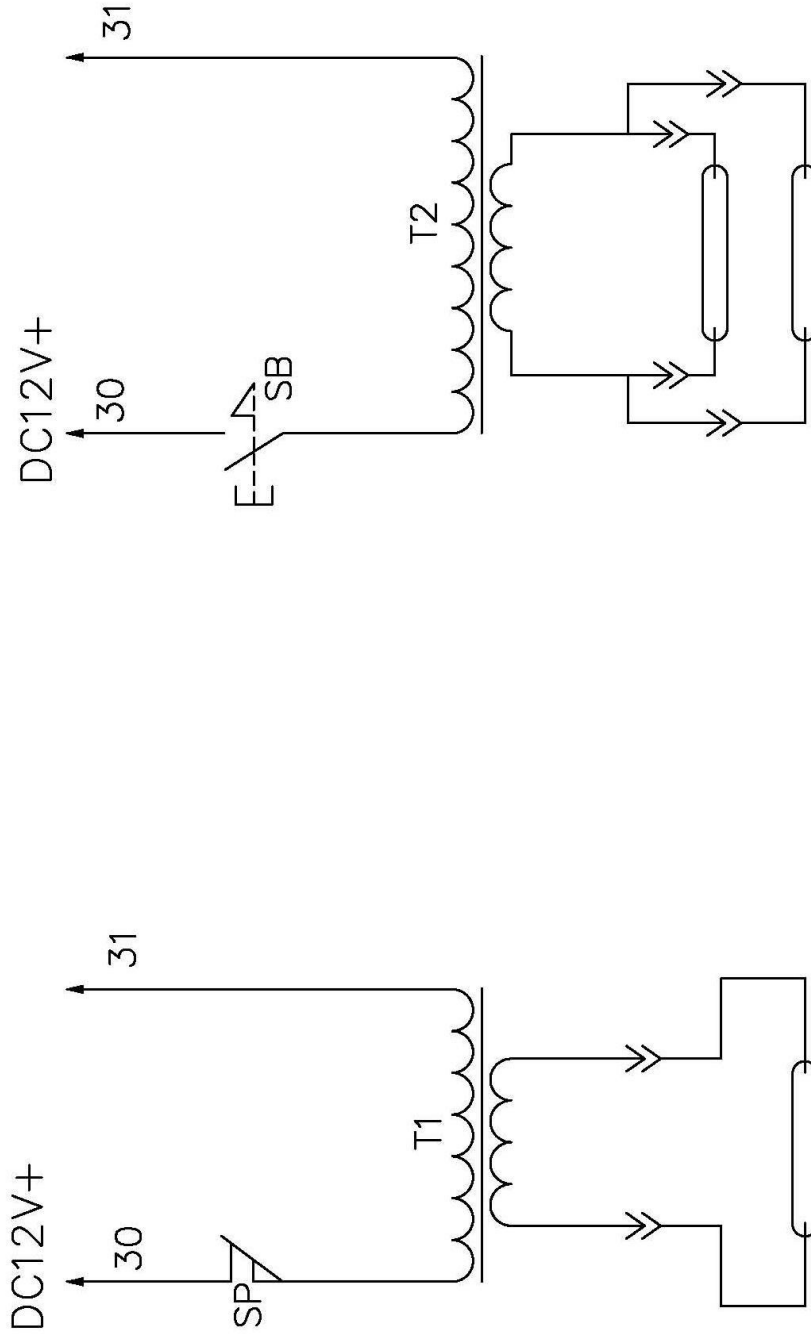

LIGHTING LAMP FOR REPAIRING

REMARK: THE AUTO ON/OFF SWITCH SP OF THIS REPAIRING LAMP IS UNDER THE INSPECTION COVER.

LIGHTING LAMPS FOR PRINTING

REMARK: THE ON/OFF SWITCH OF PRINTING LAMPS IS LOCATED AT THE RIGHT PROTECTION COVER.

**Chapter**  
**3**

# Installation, Setting & Adjustment

**INSTALL THE MACHINE & INITIAL SETUP**



1. If your machine is with a stand, install the leveling foot pads through the foot pad holes, preferably in an air-conditioned clean room with temperature around 18-28°C. Otherwise, you can simply put the machine on a table.

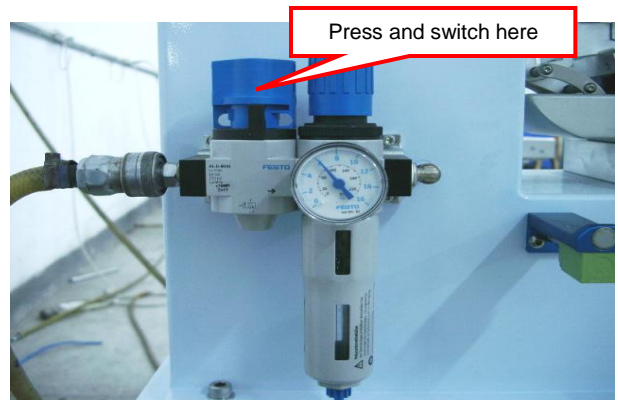

2. Connect the machine with air compressor (at least 1hp for this machine) and then input compressed air by simultaneously pressing and switching the air inlet clockwise.



3. Pull up and twist the pressure knob to get the pressure around 6.5 – 7 bar. Press down the knob when you get the desired pressure.

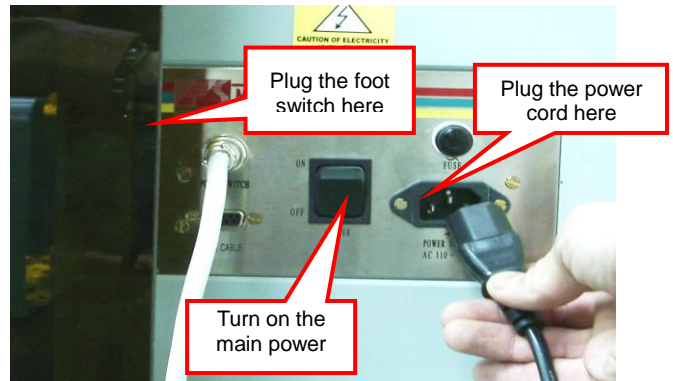

4. Plug-in the foot switch, power cord and connect with the proper power source. Then, turn on the main power switch.

**INSTALL INK CUP & PLATE**



1. Fill the ink cup with ink and place the printing plate/sub-plate face down onto the cup allowing the magnets to grip it. Make sure to use the rear of the plate to avoid any damage to the printed section of the cliché.

2. Place the ink cup/sub-plate assembly onto the machine with the etched portions forward, and the cup to the rear.

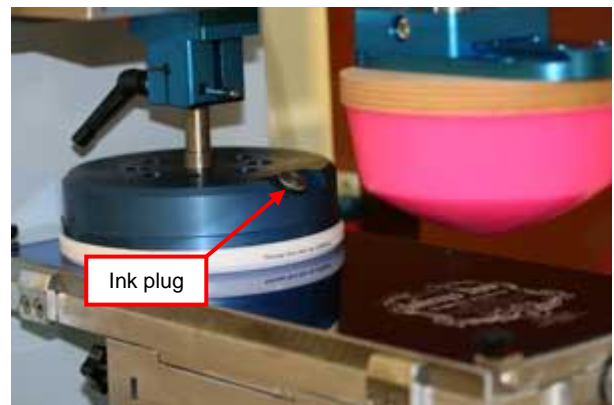
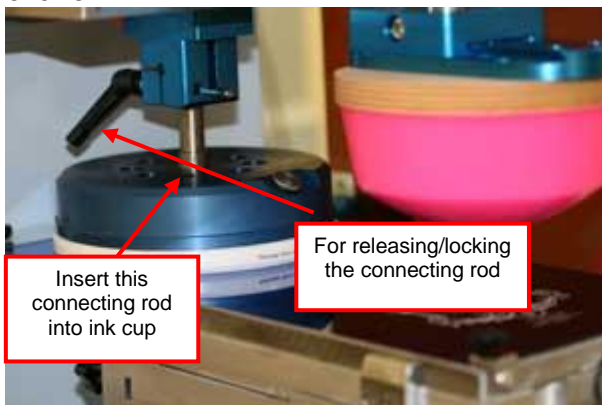

3. You can adjust the position of the drive pin assembly by loosening the orange handle and sliding it. Then loosen the black handle and drop the drive pin into the collar of the inkcup. Remember to tighten both handles before operation. At this time you can press the Pad Forward button and the pad will shuttle forward to the forward, or printing, position and the machine is ready for operation.

4. If you want to add inks or thinners during printing, you can twist off the ink inlet cover and pour ink into the ink cup through here.



**SET THE INK CUP POSITION**

After installing ink cup & etched plate on the base plate, you should align the ink cup so that it is on the center top of the base plate. If the ink cup is installed outside of the steel plate, ink will leak out.

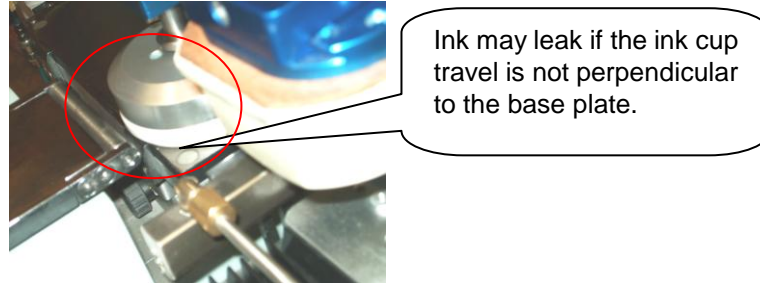

The following diagrams are indicating the correct position of ink cup and plate:

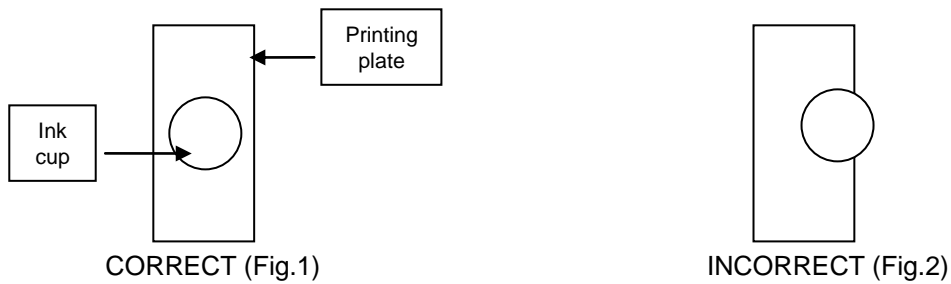

To position the ink cup in x-axis, loosen the red locking handle and then move the ink cup positioning block left or right. Lock back the locking handle afterward.

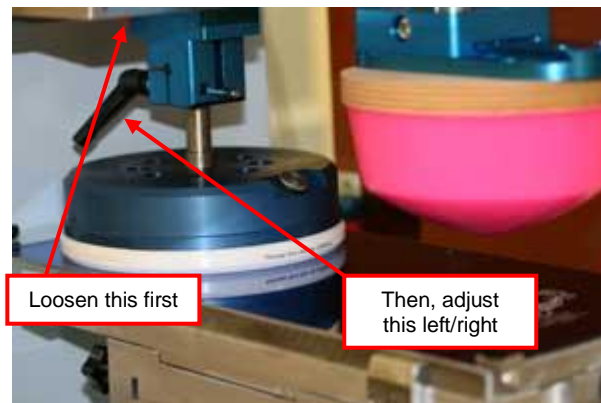

**DISMOUNT INK CUP & PLATE**

In any case, if you want to remove the ink cup or plate, make sure that you have followed the following procedures. Otherwise, it is easy to damage the ceramic cup ring and the plate.



1. Loosen the black locking handle and pull up the connecting rod. It is always suggested that you take out the ink cup with the etched plate in order to prevent ink leaking.

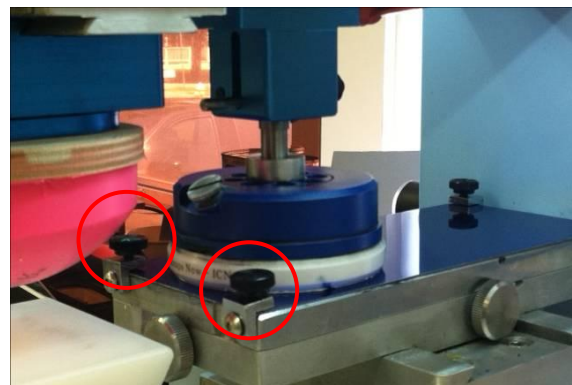

2. To take out the ink cup with thin steel plate, loosen the 2 small locking clips in the front. Then, hold up the etched plate through a crack at back of the base plate and then take out the etched plate with ink cup.

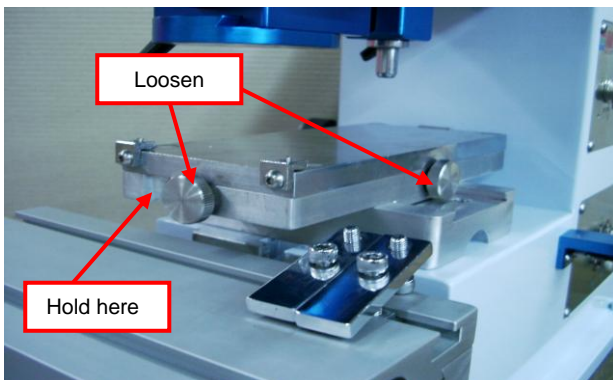

3. In any case, if you want to take out the thick base plate, loosen the 2 base plate locking screws and hold it up through the crack in front of the adjustable base and pull it out. But it is not suggested to take out the thick base plate frequently.

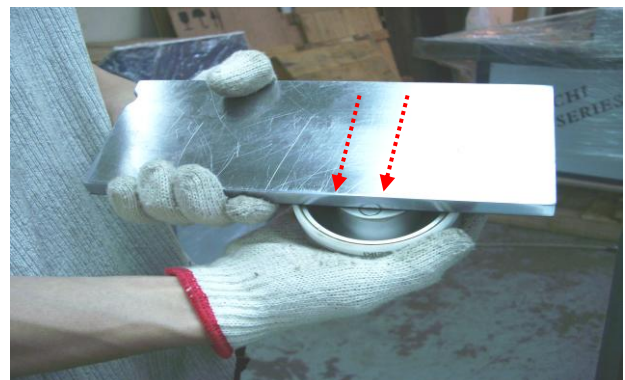

4. If you want to separate the ink cup from the etched plate, make sure that the cup is facing up, the vent plug closed and the etched plate is on top of it in order to prevent ink leaking. Then, slide the cup to the side of the thin steel plate and finally slide out from the plate. Never try to forcefully pull out the ink cup. This will damage the thin steel plate and the ceramic cup ring.

**INSTALL & SET THE PRINTING PAD**

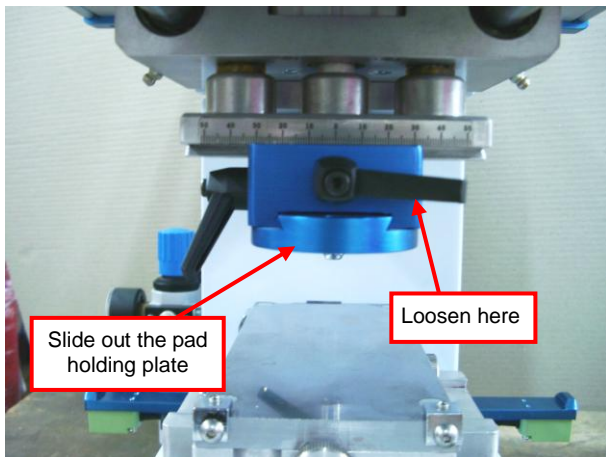

To get the pad in/out, loosen the pad locking handle and slide out the pad holding plate.



To attach the printing pad, take out the pad holding plate as shown on left and then attach the pad under the plate by using a screwdriver. There is a M6 hole in the centre of the pad holding plate. If your pad is built-in with a M6 screw, you can simply put your pad through this hole.

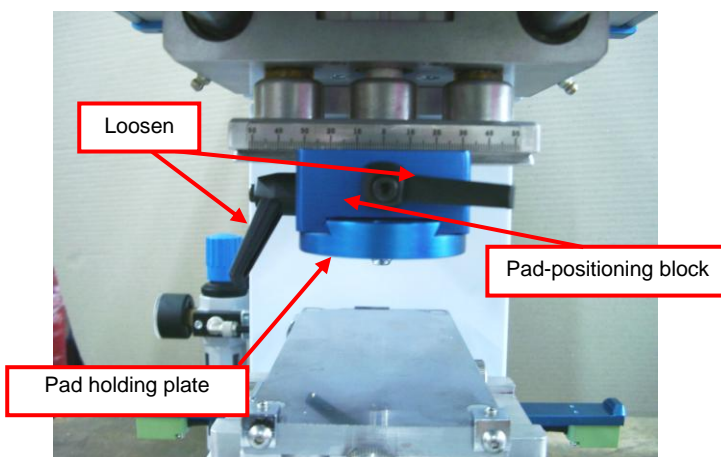

To set the pad's position, loosen the 2 locking handles. Then, adjust the pad holding plate for y-axis setting or the pad-positioning block for x-axis setting. Make sure that the printing pad is on the center top of the etched diagram.

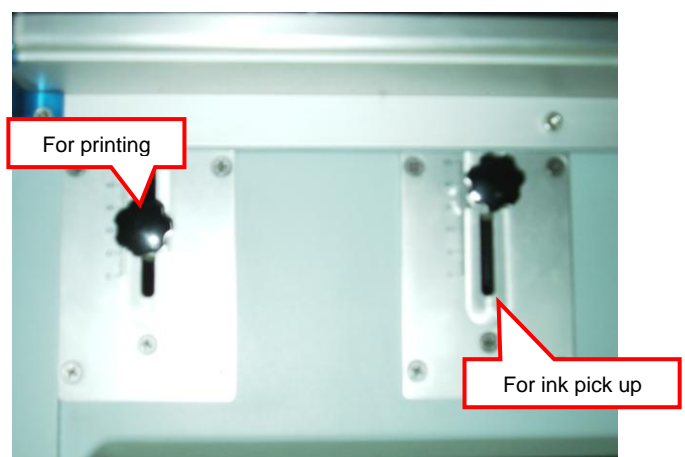

To set the pad downward stroke, loosen the respective "pad downward stroke adjusters" located at the side of the machine, then set and tighten. The one in front is for printing and the one at back is for ink pick up. We suggest you to set this stroke when the machine is not running in order to protect the machine.

**INSTALL FIXTURE**

After installing ink cup, steel plate and pads, you should now install the fixture on the worktable. There are 2 clips on the worktable for mounting the fixture. Loosen the cap screws and adjust the clips to a suitable position in order to fit your jig.



**SET & ADJUST THE WORKTABLE**

You should set the worktable's position so that the pads are just on the center top of the printing item when the pads come out and print.

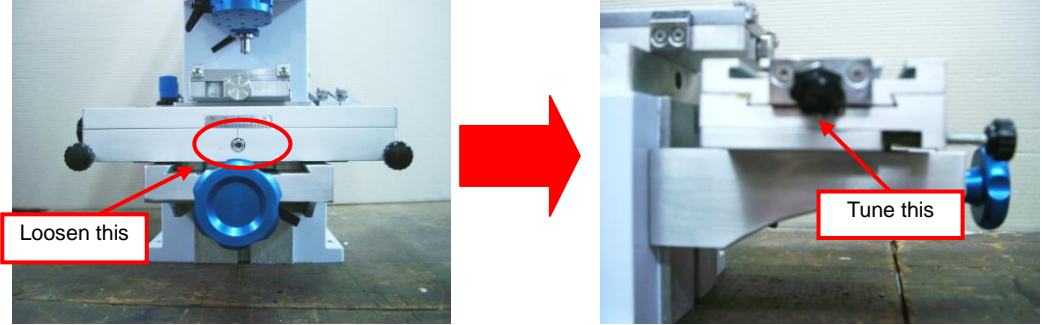
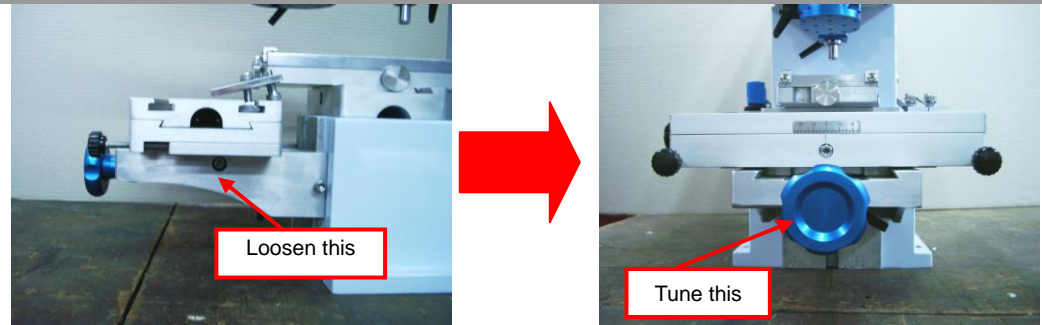
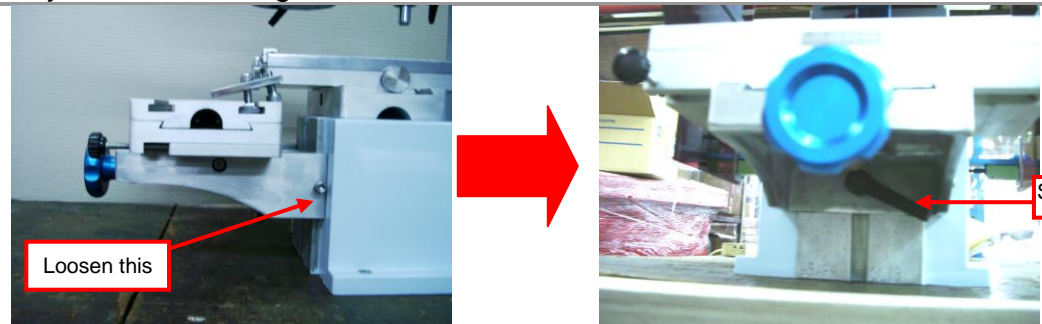
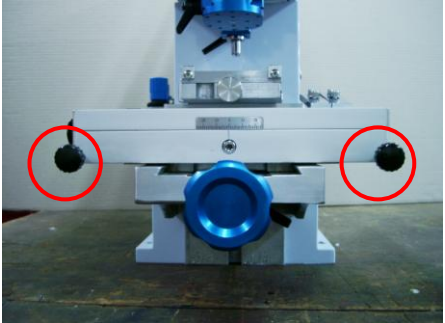
<p><b>X-axis:</b></p>	<p>Loosen the cap screw in front of the worktable (on top of the big blue adjusting knob) and then tune the black adjusting screw located at the left side of the worktable:</p> 
<p><b>Y-axis:</b></p>	<p>Loosen the cap screw at right side and then tune the big blue adjusting knob in front of the worktable for y-axis positioning:</p> 
<p><b>Z-axis:</b></p>	<p>Loosen the cap screw at right side and then use the locking handle under the table to set your desired height of worktable:</p> 
<p><b>Angle:</b></p>	<p>The 2 black adjusting screws in front of the worktable are for angle adjustment:</p> 

Remember to lock up the corresponding handles or screws after setting or adjustment.

**Chapter**  
**4**

# Operating Your Machine

## CHOOSE YOUR DESIRED PRINTING PROGRAM

When the machine is initially turned on, you can press **START/STOP** to turn the machine into ready mode. Then, the pad will be moved out and the green **READY** signal light will be flashing. This indicates that the machine is ready for work.

Under the ready mode, you can press the **PROG.** button to choose your desired printing program. Program 0 is the basic single color printing function. Although there are other programs from 1 to B, we have disabled these programs because they are not applicable to this model. The chosen program will be shown on the indicator next to it. Then, press **START/STOP** again to start printing and you will see that the **READY** signal light will be always ON during the work.

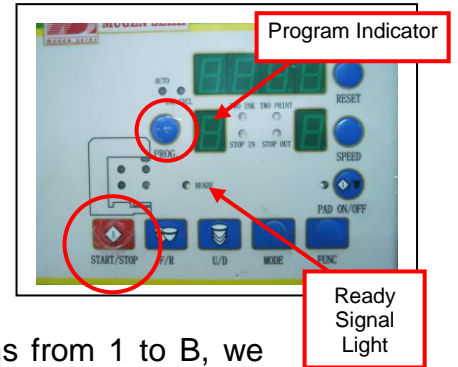

If you want to change the current printing program or any other settings when the machine is running, please stop the machine first by pressing **START/STOP** again. When the green **READY** signal light is flashing, you can change the settings.

## SET THE FREQUENCY OF INK PICK UP AND PRINTING

In order to suit for your different printing needs, you can set the printing pad to pick up ink and print once or twice. If you want to set this, make sure that the pad is ON by checking if the **PAD ON/OFF** signal light is on or off. If it is off, you can press the **PAD ON/OFF** button to make it on. Then, you can press the **FUNC** key to set the frequency of ink pick up and printing. The setting is indicated by the **TWO INK** and **TWO PRINT** signal lights:

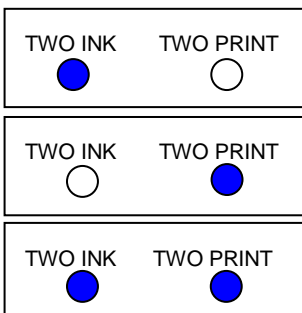
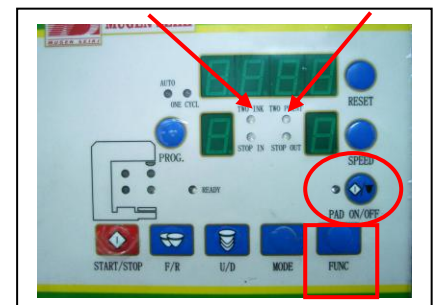

- ➔ The pad will pick up ink twice but print once.
- ➔ The pad will pick up ink once but print twice.
- ➔ The pad will pick up ink twice and print twice.

**SET TO PRINT CONTINUOUSLY OR TO PRINT IN SINGLE CYCLE**

If you need time to change the printing object, you can set the machine to print continuously so that you do not need to start and stop the machine frequently. But if you need time to change the printing item or if you are not very familiar with your job, you can also set the machine to print in single cycle.

Same as above, make sure that the pad is ON by pressing **PAD ON/OFF** button. Then, if you want to:

- ❖ Print continuously – press **MODE** to switch on the **AUTO** signal light and press **START/STOP**. The machine will print continuously and stop only when you press **START/STOP** again. It is set to print continuously when you initially turned on the machine.
- ❖ Print in single cycle – press **MODE** to switch on the **ONE CYCL** signal light and press **START/STOP** to start printing. The machine will stop automatically after printing one cycle.



**SET THE STOPPING POSITION DURING SINGLE CYCLE PRINTING**

During single cycle printing, you can select the pad stopping at inside or outside. To do this, press OFF the pad first until you see the **PAD ON/OFF** signal light is off. Then, press the **FUNC** key to switch the **STOP IN** and **STOP OUT** signal lights to the one that you want. The implication of this setting is inking or not inking the plate before the next cycle in order to suit your different printing needs.



**SET TO PRINT OR TO INK THE PLATE ONLY**

When the machine is initially turned on, it is supposed to do printing and you will see the **PAD ON/OFF** signal light is ON. But sometimes, you might need to ink the plate only without printing in case of:

- ❖ Stop printing temporary but will resume later. In this case, we suggest you to set the machine inking the plate in order to keep the etched area of the plate from drying up.
- ❖ Setting of printing pressure, you need to check whether the ink on the non-etched area of the plate is cleared up by the blade or ink cup.
- ❖ For ink cup models, after adding thinner or ink during the printing process, you want to mix well the ink.



If you just want to ink the plate without printing, you can turn off the pad by pressing **PAD ON/OFF** and you will find the signal light is OFF. Then, press **START/STOP** to start inking. Same as printing, it will ink the plate continuously if the machine is in auto mode and **AUTO** signal light is ON. If the machine is in single cycle mode and **ONE CYCL** signal light is ON, the machine will ink the plate once only.

**SET DELAY TIME**

When the **PAD ON/OFF** signal light is ON, you can press **SPEED** to set the delay time before the pad goes down from top, no matter the pad is at inside or outside. The duration chosen will be shown on the speed indicator. “0” is shortest duration and “9” is longest.

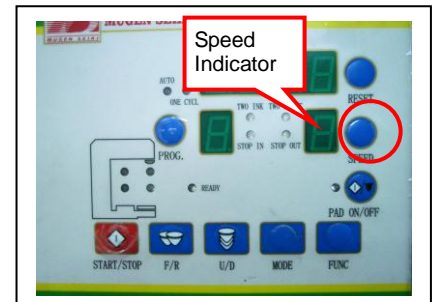

**MANUALLY OPERATING THE PAD**

In any cases, you can manually operate the pad so as to check if the pad’s position is correct or not. For manual operation, you can press:

- F/R** → To move pad forward or backward.
- U/D** → To move pad downward and then upward.



**USE OF COUNTER**

There is a counter to count the number that you have printed. If you want to reset the numbers to zero, you can press the **RESET** button next to it.



**USE OF FOOT SWITCH**

If you hands are not free to press the **START/STOP** button, you can also step on the foot switch to start or stop the machine. The foot switch is protected against any unintended stepping. You should step on the switch located at the lower level, instead of stepping on the top guard.



**USE OF EMERGENCY SWITCH**

There is an emergency switch installed in front of the control panel. In case of emergency, you can stop the machine immediately by pressing this switch. Release this before you start the machine again.



**USE OF SIDE PROTECTION COVER**

There are 2 protection covers installed at 2 sides of the machine in order to guard for any injury by putting your hands into a moving machine. If any of the covers are opened or not locked, the machine will stop running. If you want to start the machine, make sure that the 2 covers are locked in place.



**SPEED UP THE PADS' MOVEMENT**

If you want to speed up the pads' movement, you can adjust the air control valves on the speed control unit located at the right side of the machine. By turning the air valves clockwise, you can slow down the speed. While turning it anti-clockwise is to speed up.



**LIGHT UP IN PRINTING**

If you find that it is too dark for operation, you can light up the printing environment by pressing the "LAMP" button.





**Chapter****5**

# Tips for Maintaining Your Machine

- ❖ Remember to tighten adjustable handles after you have made adjustment of the fixture.
- ❖ Ensure the air pressure is properly adjusted.
- ❖ Ensure the mounting of the fixture and the printing item is secure.
- ❖ Always clean up the machine before you turn it on. Check under the manual mode to see if all the parts are functioning well and if there is any abnormal noise from the machine.
- ❖ When water is accumulated in the filter, you should frequently release it by twisting the nut under it. Otherwise, too much water will damage the pneumatic parts and hence the operation of the machine.
- ❖ After a day of work, clean up the ink cup, etched plate and the printing pad. Clean the etched plate before storing up. Then, shut off air and power.
- ❖ Periodically add lubricating oil to those moving parts, such as the shafts and bearings.



**Chapter**  
**6**

# Troubleshooting Guide

**PRINTING PROBLEMS TROUBLESHOOTING**

PROBLEM SYMPTOMS	POSSIBLE CAUSE	LIKELY SOLUTION
Printing pad does not pick up ink firmly	❖ Ink is too thick. ❖ Ink is dried in the etching. ❖ Used wrong thinner.	❖ Add more thinner. ❖ Clean the plate with thinner. ❖ Use a slower thinner or the one that corresponds to the ink type.
	❖ Etching depth on the plate is too low. ❖ Plate surface is mechanically damaged.	❖ Etch a new plate with bigger depth.
	❖ Printing pad is too flat. ❖ The pad surface is roughened.	❖ Use a more pointed pad. ❖ Printing pad is worn out. Use a new pad.
	❖ Pad stroke is adjusted too fast.	❖ Adjust the pad stroke to a slower speed.
Printing pad releases the ink film badly	❖ Ink is dried on the pad. ❖ It's too wet on the pad – unable to stick.	❖ Use a slower drying thinner. ❖ Use a faster drying thinner.
	❖ Etching depth on the plate is too low.	❖ Etch a new plate with bigger depth.
	❖ Used a wrong shape pad. ❖ The pad surface is roughened.	❖ Use a more pointed pad. ❖ Printing pad is worn out. Use a new pad.
	❖ The surface of printing item is dirty, greasy or hand sweat.	❖ Clean the item before printing. If necessary, wear gloves during printing.
	❖ Printing frequency is too slow. ❖ Room temperature is too high.	❖ Keep regular cycle times. ❖ The room temperature is best at 18-23°C.

PROBLEM SYMPTOMS	POSSIBLE CAUSE	LIKELY SOLUTION
Fine lines flow together	❖ Ink is too thick. ❖ Ink dries too slow and smears out.	❖ Reduce the amount of thinner. ❖ Use a faster drying thinner.
	❖ Etching depth on the plate is too deep. ❖ Used wrong plate type.	❖ Etch a new plate with lower depth. ❖ Use a different type of plate.
	❖ Used a wrong shape pad. ❖ The pad surface is roughened.	❖ Use a hard and pointed pad. ❖ Printing pad is worn out. Use a new pad.

**MACHINERY PROBLEMS TROUBLESHOOTING**

PROBLEM SYMPTOMS	POSSIBLE CAUSE	LIKELY SOLUTION
The LED does not illuminate after switching on the power supply	❖ Fuse is broken ❖ Poor contact of power switch	❖ Check if the plug & socket are connected correctly and if the transformer & power switch is short-circuited. If not, change the fuse. ❖ Change the power switch
The machine does not work after pressing <b>START/STOP</b> key on the front panel.	❖ Malfunction of circuit board ❖ Air pressure is not enough ❖ Solenoid valve is broken. ❖ Proximity switch is damaged ❖ Position of proximity switch is shifted ❖ Protection covers at two sides of machine are opened or not properly covered ❖ Proximity switch of the protection cover is damaged	❖ Change the circuit board. ❖ Check the pressure gauge to see if the air input is enough. ❖ Change the solenoid valve. ❖ Disconnect the air supply and use a screwdriver to approach the proximity switches. LED on the switch should illuminate if it is working. ❖ If the proximity switch is working, try to pull out the printing head by hand and check if the position of proximity switch is changed. If so, set it to a proper position. ❖ Close the protection covers properly to trigger the proximity switches. Otherwise, change the proximity switch.

PROBLEM SYMPTOMS	POSSIBLE CAUSE	LIKELY SOLUTION
Printing head slides down when it is moving forward or backward.	<ul style="list-style-type: none"> <li>❖ Malfunction of proximity switch located at S2 or S3.</li> <li>❖ Circuit board or I.C. fails to work.</li> </ul>	<ul style="list-style-type: none"> <li>❖ Change proximity switch.</li> <li>❖ Change circuit board or I.C.</li> </ul>
Printing head cannot move downward.	<ul style="list-style-type: none"> <li>❖ Malfunction of proximity switch located at S1 or S3.</li> <li>❖ Solenoid valve is broken.</li> </ul>	<ul style="list-style-type: none"> <li>❖ Change proximity switch.</li> <li>❖ Change solenoid valve for up/down movement.</li> </ul>
Printing head moves downward beyond the control of proximity switch.	<ul style="list-style-type: none"> <li>❖ Failure of proximity switch located at S1 or S4.</li> </ul>	<ul style="list-style-type: none"> <li>❖ Change proximity switch.</li> </ul>
Conveyor is getting stuck and cannot move.	<ul style="list-style-type: none"> <li>❖ The position of chain is incorrect after conveyor is adjusted.</li> <li>❖ Something wrong with the cylinder inside the conveyor.</li> <li>❖ There may be stuffs inside the conveyor.</li> </ul>	<ul style="list-style-type: none"> <li>❖ Adjust the conveyor locking screws on left/right side of conveyor.</li> <li>❖ Change the cylinder.</li> <li>❖ Remove the stuffs.</li> </ul>
No power supplied to the hot air control unit.	<ul style="list-style-type: none"> <li>❖ Fuse is short-circuited.</li> <li>❖ Power switch or the plug of this unit is broken.</li> </ul>	<ul style="list-style-type: none"> <li>❖ Check if the heating tube and heating indicator is short-circuited. If not, change fuse.</li> <li>❖ Change the hot air control unit, power switch or power plug.</li> </ul>
Only cool air is blowing. No hot air blowing.	<ul style="list-style-type: none"> <li>❖ Fuse is short-circuited.</li> <li>❖ Heating tube is burned out.</li> <li>❖ Ammeter is burned out.</li> </ul>	<ul style="list-style-type: none"> <li>❖ Check if the heating tube and heating indicator is short-circuited. If not, change fuse.</li> <li>❖ Change the heating tube.</li> <li>❖ Change the ammeter.</li> </ul>
Printing head only moves forward and stop there when you turn on the main power switch.	<ul style="list-style-type: none"> <li>❖ Foot switch is short-circuited.</li> <li>❖ <span style="border: 1px solid red; padding: 2px;">START/STOP</span> key on the front panel is short-circuited.</li> </ul>	<ul style="list-style-type: none"> <li>❖ Change the foot switch.</li> <li>❖ Change the circuit board.</li> </ul>

**Chapter**  
**7**

# Spare Part Listing

Part Description	ICN part #	Qty. Per Machine
Doctor Carriage Air Cylinder	1010	1
Print Pad Air Cylinder	1011	1
Pneumatic Valve	1012	2
Main Air Manifold	1013	1
Air Manifold Banjo Bolt	1014	2
Air Manifold Sealing Ring	1015	4
Filter Regulator Assembly	1016	1
Air Shut Off Valve	1017	1
Shock Absorber	1018	2
Flow Control Valve	1019	4
Air Gauge	1020	1
1/8" Metal Elbow Fitting	1021	4
1/4" Metal Elbow Fitting	1022	1
1/8" Straight Fitting	1023	4
Main Circuit Board	1024	1
Power Transformer	1025	1
9-12V Inverter	1026	2
Plate Area Lamp	1027	2
Fuse Holder	1028	1
Red Indicator Light	1029	2
Micro Switch (Inspection port)	1030	1
Rocker Switch (Power On)	1031	1
Proximity Switch Pad Carriage	1032	4
Proximity Switch Safety Door	1033	2
Power Socket - 110V Female	1034	1
Foot Switch Connector	1035	1
Foot Switch Assembly	1036	1
Oil Seal	1037	4
Grease Nipple	1038	2
Handle Pad Adj. Front to Back	1039	1
Handle Pad Adj, Left to Right	1040	1

Handle Pad Adj. Cup Drive Pin Lock	1041	2
Handle Adj. Cup Left to Right	1042	1
Dovetail Clamp Plate (adj handles)	1043	3
Pad Mount Assy Complete	1044	1
Cup Drive Assy Complete	1045	1
Pad Mount Plate (Dovetail)	1046	1
Locking Handle Spacer Bushing (Short)	1047	2
Locking Handle Spacer Bushing (Long)	1048	1
Pad Height Adj Knob	1049	2
Pad Height Adt T-Nut	1050	2
Bushing Pad Up/Down	1052	4
Pad Shaft (Up-Down)	1053	2
Pad Shaft Sensor Flag	1054	1
Pad Shaft Bumper	1055	2
Pad Carriage Shaft (In and out)	1056	2
Bushing Pad Carriage (In and Out)	1057	4
Safety Guard Door (Right)	1058	1
Safety Guard Door (Left)	1059	1
Safety Guard Door Sensor Mount (L&R)	1060	2
Safety Guard Shelf Bracket	1061	2
Door Sensor Actuator Plate	1062	2
Safety Door Mount Bracket	1063	2
Safety Door Hinge Set	1064	2
Cliché Holding Plate 100 X 225mm	1065	1
Cliché Holding Plate Angle Clamp	1066	4
Plate Hold Down Lock Knob (Optional)	1067	4
Cliché Holding Plate Knob	1068	2
Tooling Hold-Down Clamp	1069	2